



Full HD 1080p
MN260NV



MN260NV User Manual

About this Manual

Congratulations on purchasing the Minolta MN260NV Camcorder!

The contents of this manual are subject to change without notice. Note that the example screens and product illustrations shown in this User's Guide may differ somewhat from the screens and configuration of the actual camera.

Copyright

This manual contains proprietary information protected by copyright. All rights are reserved. No part of this manual may be reproduced by any mechanical, electronic or other means, in any form, without prior written permission of Elite Brands Inc. © 2023.

FEDERAL COMMUNICATIONS COMMISSION INTERFERENCE STATEMENT

This equipment has been tested and found to comply with the limits for a Class B digital device, pursuant to Part 15 of the FCC Rules. These limits are designed to provide reasonable protection against harmful interference in a residential installation. This equipment generates, uses and can radiate radio frequency energy and, if not installed and used in accordance with the instructions, may cause harmful interference to radio communications. However, there is no guarantee that interference will not occur in a particular installation. If this equipment does cause harmful interference to radio or television reception, which can be determined by turning the equipment off and on, the user is encouraged to try to correct the interference by one or more of the following measures:

- Reorient or relocate the receiving antenna.
- Increase the separation between the equipment and receiver.
- Connect the equipment into an outlet on a circuit different from that to which the receiver is connected.
- Consult the dealer or an experienced radio/TV technician for help.

CAUTION:

Any changes or modifications not expressly approved by the party responsible for compliance could void the user's authority to operate the equipment.

This device complies with Part 15 of the FCC Rules. Operation is subject to the following two conditions:

- (1) This device may not cause harmful interference and
- (2) This device must accept any interference received, including interference that may cause undesired operation.

RF Exposure Warning

This equipment complies with FCC RF radiation exposure limits set forth for an uncontrolled environment. This equipment must be installed and operated in accordance with provided instructions and must not be co-located or operating in conjunction with any other antenna or transmitter. End-users and installers must be provided with antenna installation instructions and transmitter operating

conditions for satisfying RF exposure compliance.

FCC: SAR standard Value: 1.6 W/Kg, Maximal Measure: 0.4 W/kg

CE Mark Warning

This is a Class B product, in a domestic environment, this product may cause radio interference, in which case the user may be required to take adequate measures.

Safety and Handling Precautions

Camera Information

- Do not disassemble or attempt to service the camera yourself.
- Do not expose the camera to moisture, or extreme temperatures.
- Allow the camera to warm up when moving from cold to warm temperatures.
- Do not touch and put pressure on the camera lens.
- Do not expose the lens to direct sunlight for extended periods.
- Do not use abrasive chemicals, cleaning solvents or strong detergents to clean the product. Wipe the product with a slightly damp soft cloth.
- Do not use the flash or LED Light near a person's eyes to prevent possible eye injury.
- To prevent you from falling over or resulting in traffic accident, please do not use the camera while you are walking, driving or riding a vehicle.
- Please handle the camera strap with care, and never place the strap around the neck of an infant or child. Wrapping the strap around a neck may cause suffocation.
- Do not subject the LCD screen to impact.
- To prevent the risk of fire or electric shock, do not expose this appliance to rain or moisture.

Battery Information

- Turn off the camera before installing or removing the battery.
- Use only the provided batteries or type of battery and charger that came with your camera. Using other types of battery or charger may damage the device and invalidate the warranty.
- Inserting the battery upside down can cause damage to the product and possibly cause an explosion.
- When the camera is used for an extended period of time, it is normal for the camera body to feel warm.
- Download all pictures and remove the battery from the camera if you are going to store the camera for a long period of time.
- The type of battery and the battery power level may cause the lens to be stuck up. Ensure you use the correct battery type and use a fully charged battery.
- Risk of explosion if battery is replaced by an incorrect type. Dispose of used batteries according to the instructions.
- Please keep the batteries out of the reach of children to prevent from swallowing

batteries, which might cause poisoning.

- Once the battery's color changes or its shape is twisted, please stop using it.

USB adapter Information

- Do not expose the adapter to high temperatures or moisture places. Otherwise, it may cause fire or electric shock.
- Do not attempt to repair, disassemble, change or transform the adapter.
- Avoid sudden changes in temperature, which may cause condensation on the adapter's internal surfaces. Please do not use it immediately in this situation.
- Do not touch the plug with wet hands. Otherwise, it may cause electric shock.
- Do not use the travel voltage converter or AC/DC power inverter. Otherwise, it may cause damage, overheating, malfunction or fire to the camera.

1.1 Camcorder Interface

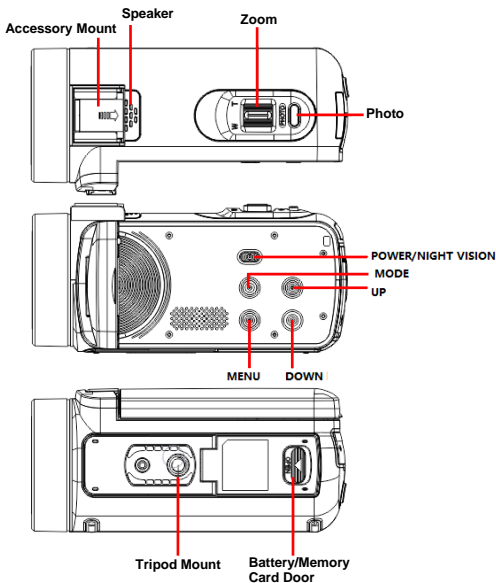
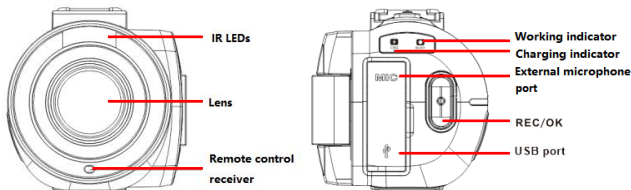

1.2 Button Function Description

Function	Description
Power IR	Tap once to power on, press and hold for 2 seconds to power off. While powered on, tap once to enable or disable IR night vision.
Mode	Tap to cycle between Video, Photo, Playback and Setup modes.
Menu	Tap to access and exit all menus and submenus.
Zoom	In Video or Photo: Press right to zoom-in. Press left to zoom-out. In Playback: While viewing a photo, slide to the right to zoom in on the photo, slide to the left to zoom out. In Video Playback: While playing a video, press to increase or decrease the volume.
Record OK	In Video: Tap to start/stop recording video. In Playback: Tap to play a recorded video, tap again to stop the video. OK button in menus. Tap to confirm a setting
Photo	In Photo: Tap to capture a photo. In Playback: While playing a recorded video, tap to pause and tap again to resume
UP	In Photo and Video: Tap to increase the exposure value. In Playback: Tap to scroll through captured media. Tap to scroll through menus and submenus.
Down	In Photo and Video: Tap to increase the exposure value. In Playback: Tap to scroll through captured media. Tap to scroll through menus and submenus.
Infrared LEDs	Infrared LED to aid with vision and recording in darkness.
Tripod Mount	Mount port for attaching to a tripod nut.

Battery/Memory Card Door	Door to cover storage slot for inserting the battery and a memory card.
Battery Release Switch	Slide the switch to remove the battery.
Speaker	Built-in speaker output for playback of video files when audio recording is enabled.
Lens	Front capture device for all video and photo.

2. First Use

2.1 Inserting the Memory Card

Insert the included SD memory card to record and store your videos and photos. When the battery is low, media stored on the memory card will not be erased. Please insert the SD memory card by following the steps below:

1. Open the memory card door on the bottom of the camcorder by flipping it down.
2. Insert the memory card. Ensure that the metal contacts are inserted first. Push the memory card down until you hear an audible click.

The memory card can only be inserted in one way. Do not force the card in if it will not go in smoothly.

3. Close the memory card door by flipping it back into place.
4. To remove the memory card, simply push in and the card will eject back out.

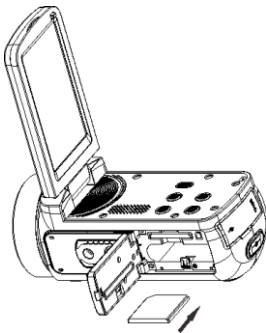

NOTE:

- Please format the memory card before using the camcorder (Caution, this will erase all data on the card).
- Do not remove or insert the memory card when recording. It may damage the card or cause data loss.
- Memory card rating must be Class 10 or above.

2.2 Installing the Battery

Insert the lithium-ion battery into the battery compartment with the metal contacts facing the back of the camcorder. Take special note of the ridges on the sides of the battery and the on the body of the camcorder. The battery can only be inserted one way. Mount the battery as shown and push in and up until it locks into place.

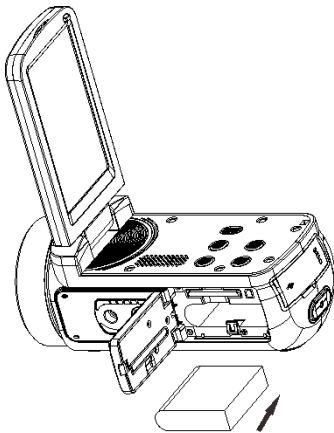

2.3 Charging the Battery

Connect your camcorder to the included AC adaptor with the USB cable provided for charging. Open the camcorder LCD screen to access the charging port. Flip down the charging port door to access the USB port. Insert the small end of the USB plug into the camcorder's port, and the larger end into the included AC adaptor.

2.4 Powering the Camcorder On/Off

Press the **POWER** button to power the camcorder on. To power the camcorder off, press and hold the **POWER** button for 2 seconds.

The camcorder will automatically power on and off when the screen is opened or closed. If the camcorder's battery is low, a "Low Power" message will display on the screen and it will automatically shut down within a few seconds to prevent memory corruption or loss.

2.5 Switching Modes

Press the **MODE** button to cycle between Video, Photo, Playback and Setup Modes. The corresponding mode will be displayed in the top left corner of the screen. You may also tap the corresponding mode icon in the top left corner of the touch screen to change modes.

2.6 Connecting to a Computer

Your camcorder can connect to a computer to transfer photo and video files for viewing and editing or you can also use the camcorder as a webcam. Once connected and powered on, the camera's screen will show "MSDC" and "PC camera". Use the **UP** or **DOWN** buttons to select your desired mode. Press the **RECORD/OK** to select your desired mode.

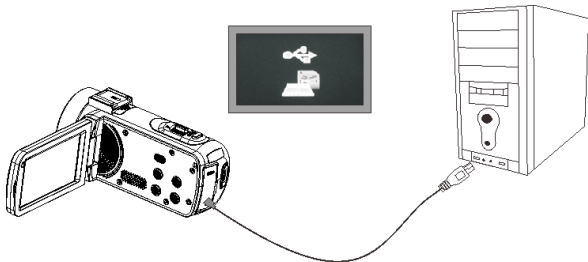

2.7 Video Mode

Press the **MODE** button to switch to Video Mode. The meaning of each icon within Video Mode is explained in the table below:

1) Video Mode	7) Zoom Indicator	13) White Balance
2) Video Size (Resolution)	8) Battery Level	14) Menu
3) Beauty Filter Icon	9) Effect	15) Current Date and Time
4) IR Light Indicator	10) Sharpness	16) Loop Recording
5) Recording Time Remaining	11) ISO	17) External Mic Connected
6) Memory Card Inserted	12) Exposure	



2.8 Photo Mode

Press the **MODE** button to switch to Photo Mode. The meaning of each icon within Photo Mode is explained in the table below:

1) Photo Mode	8) Number of Photos Remaining	15) Exposure
2) Photo Size (Resolution)	9) Memory Card Inserted	16) Image Quality
3) Beauty Filter	10) Zoom Indicator	17) White Balance
4) Anti-Shake	11) Battery Level	18) Menu
5) Face Detection	12) Effect	19) Current Time and Date
6) Smile Capture	13) Sharpness	20) Self Timer
7) IR Light Indicator	14) ISO	



2.9 Using the Zoom Function

This camcorder has a digital zoom function. To operate the zoom function, slide the **ZOOM** button right to zoom in closer to the subject, and to the left to zoom away from the subject.

2.10 Using the IR Night Vision Mode

This camcorder has built-in infrared (IR) LEDs for night vision recording - giving you the ability to capture photos and videos in a dark environment.

In Photo or Video mode, short-press the **POWER/IR** button once to enable the IR LED light. When the IR LED light is enabled, the IR LED light indicator on the top of the screen will be displayed.

To disable the IR light, short-press the **POWER/IR** button again. You will notice that the IR light indicator on the screen is no longer showing.

Note:

The photos and videos taken while the IR LED is enabled will be recorded in black and white.

The IR LED can also be enabled or disabled during a recording.

2.11 Attaching External Accessories

This camcorder supports lens filters & attachments, external microphones and assistive lighting utilizing power from the hot-shoe mount. When attaching an external microphone, be sure to mount it to the hot-shoe mount and also insert the 3.5mm plug into the MIC port.

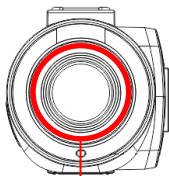

37mm Diameter
Threading

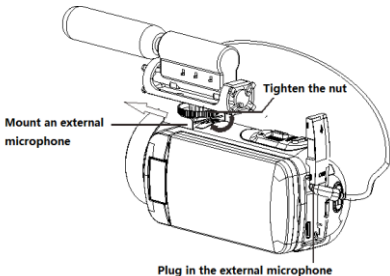

2.12 Remote Control

Note: Before using the remote, remove the battery tab on the back.

When using the remote, it should be pointed towards the remote control receiver on the front the camcorder. There shouldn't be any objects in between the remote and camcorder as they can block the signal from the remote.

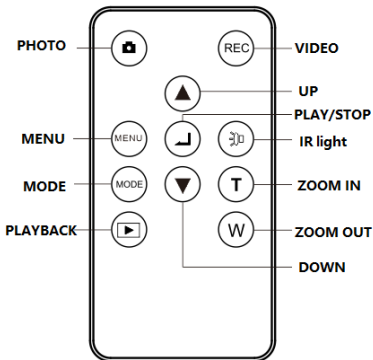

3. Using the Camcorder

3.1 Video Recording

Power the camcorder on and it will be ready to record clips right away. You may press the **MODE** button or press the icon in the top left corner of the touch screen to switch to another mode. A camcorder icon will appear in the top left hand corner of the screen when you are in Video mode.

1. Line up your shot by looking at the LCD screen to see what is in view.
2. Hold the camcorder steady and press the **RECORD** button to begin recording.
3. When recording begins, a rolling timer will display in red in the top right hand corner of the screen. This indicates the recorded video time elapsed.
4. While recording, press the **PHOTO** button to pause the recording, press the **PHOTO** button to resume recording.
5. Press the **RECORD** button to stop recording.
6. The recorded video files will automatically save onto the inserted memory card.

3.1.1 Movie Size (Resolution)

Your camcorder has a number of preset resolutions.

1. In Video Mode press the **MENU** button.
2. Select 'Movie Size' using the **UP** or **DOWN** buttons and press the **RECORD/OK** button to enter the 'Movie Size' submenu.
3. Press the **UP** or **DOWN** buttons to navigate the menu and press the **RECORD/OK** button to confirm your selected setting (*1080P*, *720P*, *480P*). A higher resolution and faster frames per second rate will produce a higher quality and larger video file.
4. Press the **MENU** button to exit the menu without making a selection.

3.1.2 Sharpness

This function adjusts the visible detail of a photograph.

1. In Video Mode, press the **MENU** button.
2. Select 'Sharpness' using the **UP** or **DOWN** buttons and press the **RECORD/OK** button to enter the 'Sharpness' submenu.
3. Press the **UP** or **DOWN** buttons to navigate the menu and press the

RECORD/OK button to confirm how sharp you would like your video to be (*Sharp, Normal, Soft*).

4. Press the **MENU** button to exit the menu without making a selection.

3.1.3 White Balance

White Balance changes the color of light in your pictures, making it seem warmer or cooler depending on how the light you're shooting in affects the frame.

1. In Video Mode press the **MENU** button.
2. Select '*White Balance*' using the **UP** or **DOWN** buttons and press the **RECORD/OK** button to enter the '*White Balance*' submenu.
3. Press the **UP** or **DOWN** buttons to navigate the menu and press the **RECORD/OK** button to confirm your selected setting (*Auto, Daylight, Cloudy, Fluorescent, Tungsten*).
4. Press the **MENU** button to exit the menu without making a selection.

3.1.4 Exposure

This function adjusts the frame brightness in your video.

1. In Video Mode press the **MENU** button.
2. Select '*Exposure*' using **UP** or **DOWN** buttons and press the **RECORD/OK** button to enter the '*Exposure*' submenu.
3. Press the **UP** or **DOWN** buttons to navigate the menu and press the **RECORD/OK** button to confirm your selected exposure mode (+3, +2, +1, 0, -1, -2, -3).
4. Press the **MENU** button to exit the menu without making a selection.

3.1.5 ISO

This function adjusts the light sensitivity in your photograph.

1. In Video Mode press the **MENU** button.
2. Select '*ISO*' using the **UP** or **DOWN** buttons and press the **RECORD/OK** button to enter the '*ISO*' submenu.
3. Press the **UP** or **DOWN** buttons to navigate the menu and press the **RECORD/OK** button to confirm your selected ISO (*Auto, 100, 200, 400*).
4. Press the **MENU** button to exit the menu without making a selection.

3.1.6 Loop Recording

This function allows you to set a maximum duration for each video clip recorded.

1. In Video Mode press the **MENU** button.
2. Select 'Loop Recording' using the **UP** or **DOWN** buttons and press the **RECORD/OK** button to enter the 'Loop Recording' submenu.
3. Press the **UP** or **DOWN** buttons to select the required loop duration option (*On, Off, Loop Duration*), and press the **RECORD/OK** button to confirm your selected option.
4. To select the length of the loop recording select 'Loop Duration' and press the **RECORD/OK** button.
5. Use the **UP** or **DOWN** buttons to select your desired loop duration and press the **RECORD/OK** button to select your desired setting (*1 Minute, 3 Minutes, 5 Minutes, 10 Minutes*).
6. Press the **MENU** button to exit the menu without making a selection.

Once you select an option, your camcorder will record video clips in this interval only. Once this duration is reached, the camcorder will seamlessly end recording and begin recording a new video file.

3.1.7 Color Effect

This function sets the color filter effect of a video.

1. In Video Mode press the **MENU** button.
2. Select 'Color Effect' using the **UP** or **DOWN** buttons and press the **RECORD/OK** button to enter the 'Color Effect' submenu.
3. Press the **UP** or **DOWN** buttons to navigate the menu and press the **RECORD/OK** button to confirm your selected filter (*Normal, B & W, Sepia, Red, Green, Blue, Sunset, Warm, Cool, Over Exposure, IR, Binary, Vivid, Undertone, Dog Eye, Aibao, Gothic, Japan Style, LOMO, Negative*).
4. Press the **MENU** button to exit the menu without making a selection.

3.1.8 Scene Mode

This function adjusts the camera's settings to predetermined values that will produce the best image for that selected scene.

1. In Video Mode press the **MENU** button.
2. Select 'Scene Mode' using the **UP** or **DOWN** buttons and press the **RECORD/OK** button to enter the 'Scene Mode' submenu.

3. Press the **UP** or **DOWN** buttons to navigate the menu and press the **RECORD/OK** button to confirm your selected option (*Auto, Night, Portrait, Landscape, Backlight, Sport, Party, Beach, High Sensitivity*).
4. Press the **MENU** button to exit the menu without making a selection.

3.1.9 Beauty Filter

This feature applies a filter effect on the people in the scene.

1. In Video Mode press the **MENU** button.
2. Select '*Beauty Filter*' using the **UP** or **DOWN** buttons and press the **RECORD/OK** button to enter the '*Beauty Filter*' submenu.
3. Press the **UP** or **DOWN** buttons to navigate the menu and press the **RECORD/OK** button to confirm your selected option (*On, Off*).
4. Press the **MENU** button to exit the menu without making a selection.

Alternatively, your camcorder's menus can be navigated via the touch screen.

3.2 Photo Shooting

Power the camcorder on and press the **MODE** button or press the icon in the top left hand corner of the touch screen to switch to Photo mode.

1. Line up your shot by looking at the LCD screen to see what is in the shot.
2. Hold the camera steady, press the **PHOTO** button to capture a photo.
3. The number of photos that can be captured at a particular resolution will be displayed in the top right corner of the screen.
4. The number of remaining photos is determined by the selected photo resolution. The higher the photo resolution, the lower the number of photos you are able to be save to the memory card. Before capturing any photos, you can select a preferred photo resolution.

3.2.1 Photo Size (Resolution)

This function sets the photo resolution. The higher the resolution, the greater the photo quality and the larger the file size of the photo.

1. In Photo Mode press the **MENU** button.
2. Select 'Photo Size' using the **UP** or **DOWN** buttons and press the **RECORD/OK** button to enter the 'Photo Size' submenu.
3. Press the **UP** or **DOWN** buttons to navigate the menu and press the **RECORD/OK** button to confirm the selected photo resolution (30MP, 24MP, 20MP, 16MP, 12MP, 10MP, 8MP, 7MP-Wide, 5MP, 3MP).
4. Press the **MENU** button to exit the menu without making a selection.

3.2.2 Quality

The Photo Quality function determines the level of compression the camcorder uses when saving photos to a memory card.

1. In Photo Mode press the **MENU** button.
2. Select 'Quality' using the **UP** or **DOWN** buttons and press the **RECORD/OK** button to enter the 'Quality' submenu.
3. Press the **UP** or **DOWN** buttons to select the required quality option (*Super Fine, Fine, Normal*), and press the **RECORD/OK** button to confirm your selected image option. Super Fine uses the least amount of compression for saving, and as a result produces a higher photo quality.
4. Press the **MENU** button to exit the menu without making a selection.

3.2.3 Sharpness

This function adjusts the visible detail of a photograph.

1. In Photo Mode, press the **MENU** button.
2. Select '*Sharpness*' using the **UP** or **DOWN** buttons and press the **RECORD/OK** button to enter the '*Sharpness*' submenu.
3. Press the **UP** or **DOWN** buttons to navigate the menu and press the **RECORD/OK** button to confirm how sharp you would like your photograph to be (*Sharp, Normal, Soft*).
4. Press the **MENU** button to exit the menu without making a selection.

3.2.4 White Balance

White Balance changes the color of light in your pictures, making it seem warmer or cooler depending on how the light you're shooting in affects the frame.

1. In Photo Mode press the **MENU** button.
2. Select '*White Balance*' using the **UP** or **DOWN** buttons and press the **RECORD/OK** button to enter the '*White Balance*' submenu.
3. Press the **UP** or **DOWN** buttons to navigate the menu and press the **RECORD/OK** button to confirm your selected setting (*Auto, Daylight, Cloudy, Fluorescent, Tungsten*).
4. Press the **MENU** button to exit the menu without making a selection.

3.2.5 ISO

This function adjusts the light sensitivity in your photograph.

1. In Photo Mode press the **MENU** button.
2. Select '*ISO*' using the **UP** or **DOWN** buttons and press the **RECORD/OK** button to enter the '*ISO*' submenu.
3. Press the **UP** or **DOWN** buttons to navigate the menu and press the **RECORD/OK** button to confirm your selected ISO (*Auto, 100, 200, 400*).
4. Press the **MENU** button to exit the menu without making a selection.

3.2.6 Exposure

This function adjusts the frame brightness in your video.

1. In Photo Mode press the **MENU** button.
2. Select '*Exposure*' using the **UP** or **DOWN** buttons and press the **RECORD/OK** button to enter the '*Exposure*' submenu.

3. Press the **UP** or **DOWN** buttons to navigate the menu and press the **RECORD/OK** button to confirm your selected exposure mode (+3, +2, +1, 0, -1, -2, -3).
4. Press the **MENU** button to exit the menu without making a selection.

3.2.7 Self Timer

This function determines the time delay before a photograph is captured. This setting can be used by photographers to take photographs of themselves.

1. In Photo Mode press the **MENU** button.
2. Select 'Self Timer' using the **UP** or **DOWN** buttons and press the **RECORD/OK** button to enter the 'Self Timer' submenu.
3. Press the **UP** or **DOWN** buttons to navigate the menu and press the **RECORD/OK** button to confirm your selected option (*Off, 2 Seconds, 5 Seconds, 10 Seconds*).
4. Press the **MENU** button to exit the menu without making a selection.

3.2.8 Photo Burst

This function allows to you capture 3 consecutive photos with one click of the **PHOTO** button.

1. In Photo Mode press the **MENU** button.
2. Select 'Photo Burst' using the **UP** or **DOWN** buttons and press the **RECORD/OK** button to enter the 'Photo Burst' submenu.
3. Press the **UP** or **DOWN** buttons to navigate the menu and press the **RECORD/OK** button to confirm your selected setting (*Single, 3-Photo Burst*).
4. Press the **MENU** button to exit the menu without making a selection.

3.2.9 Color Effect

This function sets the color filter effect of a photo.

1. In Photo Mode press the **MENU** button.
2. Select 'Color Effect' using the **UP** or **DOWN** buttons and press the **RECORD/OK** button to enter the 'Color Effect' submenu.
3. Press the **UP** or **DOWN** buttons to navigate the menu and press the **RECORD/OK** button to confirm your selected filter (*Normal, B & W, Sepia*,

Red, Green, Blue, Sunset, Warm, Cool, Over Exposure, IR, Binary, Vivid, Undertone, Dog Eye, Aibao, Gothic, Japan Style, LOMO, Negative).

4. Press the **MENU** button to exit the menu without making a selection.

3.2.10 Anti-Shake

This function enables photo capture in high speed and low-light by electronically minimizing motion blur and reducing camera shake.

1. In Photo Mode press the **MENU** button.
2. Select '*Anti-Shaker*' using the **UP** or **DOWN** buttons and press the **RECORD/OK** button to enter the '*Anti-Shake*' submenu.
3. Press the **UP** or **DOWN** buttons to navigate the menu and press the **RECORD/OK** button to confirm your selected option (*On, Off*).
4. Press the **MENU** button to exit the menu without making a selection.

3.2.11 Scene Mode

This function adjusts the camera's settings to predetermined values that will produce the best image for that selected scene.

1. In Photo Mode press the **MENU** button.
2. Select '*Scene Mode*' using the **UP** or **DOWN** buttons and press the **RECORD/OK** button to enter the '*Scene Mode*' submenu.
3. Press the **UP** or **DOWN** buttons to navigate the menu and press the **RECORD/OK** button to confirm your selected option (*Auto, Night, Portrait, Landscape, Backlight, Sport, Party, Beach, High Sensitivity*).
4. Press the **MENU** button to exit the menu without making a selection.

3.2.12 Face Detection

This function allows you to set your camera to detect faces in a scene and adjust your camera's setting for the most optimal picture. You can also enable your camera to capture a photo once a smile is detected on the faces in a scene.

1. In Photo Mode press the **MENU** button.
2. Select '*Face Detection*' using the **UP** or **DOWN** buttons and press the **RECORD/OK** button to enter the '*Face Detection*' submenu.
3. Press the **UP** or **DOWN** buttons to navigate the menu and press the **RECORD/OK** button to confirm your selected option (*On, Off*). The *On* setting will enable Face Detection.

4. Press the **MENU** button to exit the menu without making a selection.

3.2.13 Smile Capture

This function allows you to set your camera to detect smiles in a scene and for it to capture a photo automatically.

1. In Photo Mode press the **MENU** button.
2. Select '*Smile Capture*' using the **UP** or **DOWN** buttons and press the **RECORD/OK** button to enter the '*Smile Capture*' submenu.
3. Press the **UP** or **DOWN** buttons to navigate the menu and press the **RECORD/OK** button to confirm your selected option (*On, Off*). The Smile Detect setting will enable your camera to capture a photo once a smile is detected on the faces in a scene.
4. Press the **MENU** button to exit the menu without making a selection.

3.2.14 Beauty Filter

This feature applies a filter effect on the people in the scene.

1. In Photo Mode press the **MENU** button.
2. Select '*Beauty Filter*' using the **UP** or **DOWN** buttons and press the **RECORD/OK** button to enter the '*Beauty Filter*' submenu.
3. Press the **UP** or **DOWN** buttons to navigate the menu and press the **RECORD/OK** button to confirm your selected option (*On, Off*).
4. Press the **MENU** button to exit the menu without making a selection.

Alternatively, your camcorder's menus can be navigated via the touch screen.

3.3 Playback Mode

Videos and photos captured on your camcorder can be easily played back.

1. Press the **UP** or **DOWN** buttons to cycle through the captured videos and photos stored on the memory card.
2. When viewing a photo push the **ZOOM** button to the right and it will zoom in on the picture on the screen. While zoomed in, press the **RECORD** button to change the function of the **ZOOM** button, now use the **UP**, **DOWN** and **ZOOM** buttons to move the image on the screen. Use the touch screen to navigate while zoomed in.
3. Press the **RECORD** button again to change the function of the **ZOOM** button back to **ZOOM**.
4. Use the **UP** or **DOWN** buttons to move the image on the screen.

Power the camcorder on and press the **MODE** button to switch to Playback Mode. In Playback Mode the following options are available:

3.3.1 Delete

This function is used to delete photos and videos. Photos and videos can be deleted singly or all at once.

1. In Playback Mode press the **MENU** button, and use the **UP** or **DOWN** buttons to select '*Delete*'. Press the **RECORD/OK** button to enter the '*Delete*' submenu.
2. Press the **UP** or **DOWN** buttons to navigate the menu and press the **RECORD/OK** button for your selected setting (*This Image, All*).
3. Press the **MENU** button to exit the menu without deleting any pictures or videos.

3.3.2 Protect

This function protects the photo/video file. The file will be protected from being deleted accidentally. Files must be unprotected to be deleted.

1. In Playback Mode press the **MENU** button, and use the **UP** or **DOWN** buttons to select '*Protect*' and press the **RECORD/OK** button to enter the '*Protect*' submenu.
2. Press the **UP** or **DOWN** buttons to navigate the menu and press the **RECORD/OK** button to confirm your selected setting (*Lock This, Unlock This, Lock All, Unlock All*).
3. Press the **MENU** button to exit the menu without protecting any pictures or videos.

3.3.3 Rotate

This function is used to rotate images.

1. In Playback Mode press the **MENU** button, and use the **UP** or **DOWN** buttons to select 'Rotate'. Press the **RECORD/OK** button to enter the 'Rotate' submenu.
2. Press the **UP** or **DOWN** buttons to navigate the menu and press the **RECORD/OK** button for your selected setting (90°, 180°, 270°).
3. Press the **MENU** button to exit the menu without rotating the current picture.

3.3.4 Slideshow

Photographs can be viewed as a slideshow on the camcorder.

1. In Playback Mode press the **MENU**, and use the **UP** or **DOWN** buttons to select 'Slideshow' Press the **RECORD/OK** button to enter the 'Slideshow' submenu.
2. Press the **UP** or **DOWN** buttons to navigate the menu and press the **RECORD/OK** button to confirm your selected setting (3 Seconds, 5 Seconds, 10 Seconds).
3. Once the time duration has been chosen, the slideshow will start playing.
4. Press the **RECORD** button to stop the slideshow.
5. To exit the 'Slideshow' submenu, press the **MENU** button.

3.3.5 Video Playback

Videos can be played back and viewed on your camcorder.

1. In Playback Mode, press the **UP** or **DOWN** buttons to select the video file for playback.
2. Press the **RECORD/OK** button to start playing the video. Press the **RECORD/OK** button a second time to stop the video.
3. During playback, push the **ZOOM** button (left or right) to raise and lower the volume of the video.
4. During playback, press the **PHOTO** button to pause the video, press it again to resume playing.

Alternatively, your camcorder's menus can be navigated via the touch screen.

3.4 Setup Menu

Basic settings can be changed in the Setup menu. These include date & time, language and sound options. Power the camera on and press the **MODE** button, or press the icon in the top left hand corner of the touch screen to switch to setup mode. A menu will display on the screen.

3.4.1 Language

This function allows you to set the camcorder's interface language.

1. In Setup Mode use the **UP** or **DOWN** buttons to select '*Language*' and press the **RECORD/OK** button to enter the '*Language*' submenu.
2. Press the **UP** or **DOWN** buttons to select your desired language. Then press the **RECORD/OK** button to confirm your selection.
3. Press the **MENU** button to exit the menu without making a selection.

3.4.2 Date and Time

This function allows you to set the current Date and Time on your recorded video clips and captured photos.

1. In Setup Mode use the **UP** or **DOWN** buttons to select '*Date and Time*' and press the **RECORD/OK** button to enter the '*Date and Time*' submenu.
2. Press the **UP** or **DOWN** buttons to select your desired setting (*Date and Time Stamp On, Date and Time Stamp Off, Date and Time Set*), then press the **RECORD/OK** button to confirm your selection.
3. To set the current date and time, select '*Date and Time Set*' and press the **RECORD/OK** button to enter the date and time set submenu.
4. Press the **RECORD/OK** button to switch between year, month, day, hour, minute and second.
5. Once highlighted on your desired field, press the **UP** or **DOWN** buttons to cycle through numbers.
6. Once completed with all of the fields, press the **RECORD/OK** button to confirm the changes.
7. Press the **MENU** button to exit the menu without making a selection.

3.4.3 Auto Power Off

This function sets the duration of time in which the camcorder will wait with no user input before automatically powering off.

1. In Setup Mode use the **UP** or **DOWN** buttons to navigate and select '*Auto*

3. Using Your Camcorder

Power Off and press the **RECORD/OK** button to enter the '*Auto Power Off*' submenu.

2. Press the **UP** or **DOWN** buttons to navigate the menu and press the **RECORD/OK** button to confirm your selected setting (*Off, 1 Minute, 3 Minutes, 5 Minutes*).
3. Press the **MENU** button to exit the menu without making a selection.

3.4.4 Beep Sound

This function can turn the sound the camcorder makes after pressing a button, on or off.

1. In Setup Mode, use the **UP** or **DOWN** buttons to select '*Beep Sound*' and press the **RECORD/OK** button to enter the '*Beep Sound*' submenu.
2. Press the **UP** or **DOWN** buttons to select your desired setting (*On, Off*), Then press the **RECORD/OK** button to confirm your selection.
3. Press the **MENU** button to exit the menu without making a selection.

3.4.5 Frequency

This function sets the frequency of the camcorder from 50Hz to 60Hz. Please check the frequency of your location and set accordingly.

1. In Setup Mode use the **UP** or **DOWN** buttons to select '*Frequency*' and press the **RECORD/OK** button to enter the '*Frequency*' submenu.
2. Press the **UP** or **DOWN** buttons to select your desired frequency. Then press the **RECORD/OK** button to confirm your selection (*60Hz, 50Hz*). The default frequency for the United States is 60Hz.
3. Press the **MENU** button to exit the menu without making a selection.

3.4.6 Format Memory Card

The format setting erases all photos, videos and data stored on your memory card.

1. In Setup Mode use the **UP** or **DOWN** buttons to select '*Format Memory Card*' and press the **RECORD/OK** button to enter the submenu.
2. Press the **UP** or **DOWN** buttons to navigate the menu and press the **RECORD/OK** button for your selected setting (*Yes, No*).
3. Press the **MENU** button to exit the menu without making a selection.

NOTE: This will delete all of your media and cannot be undone.

3.4.7 Restore Default Settings

Factory default settings can be restored in this menu. This function will not delete the media stored on the memory card, and will only restore all of the menu's setting back to factory default settings.

1. In Setup Mode use the **UP** or **DOWN** buttons to select '*Restore Default Settings*' and press the **RECORD/OK** button to enter the '*Restore Default Settings*' submenu.
2. Press the **UP** or **DOWN** buttons to navigate the menu and press the **RECORD/OK** button to confirm your selection (*Yes, No*).
3. Press the **MENU** button to exit the menu without making a selection.

3.4.8 Touch Screen Calibration

The LCD touch screen can be calibrated by following these steps.

1. In Setup Mode use the **UP** or **DOWN** buttons to select '*Touch Screen Calibration*' and press the **RECORD/OK** button to start calibrating the screen.
2. There will be a small plus sign that then shows in the bottom left corner of the screen, try to touch the plus sign as close to center as possible.
3. After touching that plus sign you will be prompted to touch 4 more plus signs, one in each of the remaining three corners and one in the center of the screen.
4. After touching the last plus sign, the calibration will be complete.
5. You can perform the touch screen calibration as many times as needed.

Alternatively, your camcorder's menus can be navigated via the touch screen.

4.1 Technical Specifications

Model Number	Minolta MN260NV
Lens	Fixed Focus • f=7.5mm • F/3.2 • 37mm Front Threading for Lens Accessory Attachments
Zoom	16X Digital Zoom
Image Sensor	5MP CMOS Sensor
Shutter	Electronic • Anti-Shake Image Stabilization
Pixels (photo)	JPEG: 30MP • 24MP • 20MP • 16MP • 12MP • 10MP • 8MP • 7MP • 5MP • 3MP
Pixels (video)	AVI: 1080p • 720p • VGA
ISO Sensitivity	Auto • 100 • 200 • 400
LCD Monitor	3.0 Inch IPS High Resolution Touch Screen LCD
Assistive Light	Infrared LED (for shooting in dark scenery)
Power Saving Mode	OFF • 1 Minute • 3 Minutes • 5 Minutes
White Balance Control	Auto • Daylight • Cloudy • Fluorescent • Tungsten
Scene Modes	Auto • Night • Portrait • Landscape • Backlight • Sport • Party • Beach • High Sensitivity
Special Features	Photo Burst • Face Detection • Color Filters • Anti-Shake
Accessory Shoe Mount	Yes, for external MIC or Assistive Lighting
Recording Media	SD • SDHC; Maximum: 128GB
I/O Ports	5-pin Mini USB 2.0 • 3.5mm Microphone Input
Power	NP-40; 3.7v, 1500mAh
Dimensions	4.96 x 2.36 x 2.32 in. • 9.9 oz.



MINOLTA®

Minolta is a registered trademark of JMM Lee Properties, LLC and is used in the United States by Elite Brands Inc. under license.

*40 Wall Street, 61st Floor, New York, NY 10005 USA • Tel: 800-441-1100
www.minoltadigital.com • www.elitebrands.com
Copyright © 2023 Elite Brands Inc.*

If you're having difficulties with your camera, or would like further assistance, please call our toll-free technical support hotline at 800-441-1100. Please be sure to have your camera handy when calling.





MINOLTA®

MN260NV