



Full HD 1080p  
**MN220NV**  
INFRARED NIGHT VISION



# MN220NV User Manual

## About this Manual

Congratulations on purchasing the Minolta MN220NV HD Camcorder! The contents of this manual are subject to change without notice. Note that the example screens and product illustrations shown in this User's Guide may differ somewhat from the screens and configuration of the actual camera.

## Copyright

This manual contains proprietary information protected by copyright. All rights are reserved. No part of this manual may be reproduced by any mechanical, electronic or other means, in any form, without prior written permission of Elite Brands Inc. © 2021.

## FEDERAL COMMUNICATIONS COMMISSION INTERFERENCE STATEMENT

This equipment has been tested and found to comply with the limits for a Class B digital device, pursuant to Part 15 of the FCC Rules. These limits are designed to provide reasonable protection against harmful interference in a residential installation. This equipment generates, uses and can radiate radio frequency energy and, if not installed and used in accordance with the instructions, may cause harmful interference to radio communications. However, there is no guarantee that interference will not occur in a particular installation. If this equipment does cause harmful interference to radio or television reception, which can be determined by turning the equipment off and on, the user is encouraged to try to correct the interference by one or more of the following measures:

- Reorient or relocate the receiving antenna.
- Increase the separation between the equipment and receiver.
- Connect the equipment into an outlet on a circuit different from that to which the receiver is connected.
- Consult the dealer or an experienced radio/TV technician for help.

## CAUTION:

Any changes or modifications not expressly approved by the party responsible for compliance could void the user's authority to operate the equipment.

This device complies with Part 15 of the FCC Rules. Operation is subject to the following two conditions:

- (1) This device may not cause harmful interference and
- (2) This device must accept any interference received, including interference that may cause undesired operation.

## RF Exposure Warning

This equipment complies with FCC RF radiation exposure limits set forth for an uncontrolled environment. This equipment must be installed and operated in accordance with provided instructions and must not be co-located or operating in conjunction with any other antenna or transmitter. End-users and installers must be provided with antenna installation instructions and transmitter operating

conditions for satisfying RF exposure compliance.

FCC: SAR standard Value: 1.6 W/Kg, Maximal Measure: 0.4 W/kg

## **CE Mark Warning**

This is a Class B product, in a domestic environment, this product may cause radio interference, in which case the user may be required to take adequate measures.

## **Safety and Handling Precautions**

### **Camera Information**

- Do not disassemble or attempt to service the camera yourself.
- Do not expose the camera to moisture, or extreme temperatures.
- Allow the camera to warm up when moving from cold to warm temperatures.
- Do not touch and put pressure on the camera lens.
- Do not expose the lens to direct sunlight for extended periods.
- Do not use abrasive chemicals, cleaning solvents or strong detergents to clean the product. Wipe the product with a slightly damp soft cloth.
- Do not use the flash or LED Light near a person's eyes to prevent possible eye injury.
- To prevent you from falling over or resulting in traffic accident, please do not use the camera while you are walking, driving or riding a vehicle.
- Please handle the camera strap with care, and never place the strap around the neck of an infant or child. Wrapping the strap around a neck may cause suffocation.
- Do not subject the LCD screen to impact.
- To prevent the risk of fire or electric shock, do not expose this appliance to rain or moisture.

### **Battery Information**

- Turn off the camera before installing or removing the battery.
- Use only the provided batteries or type of battery and charger that came with your camera. Using other types of battery or charger may damage the device and invalidate the warranty.
- Inserting the battery upside down can cause damage to the product and possibly cause an explosion.
- When the camera is used for an extended period of time, it is normal for the camera body to feel warm.
- Download all pictures and remove the battery from the camera if you are going to store the camera for a long period of time.
- The type of battery and the battery power level may cause the lens to be stuck up. Ensure you use the correct battery type and use a fully charged battery.
- Risk of explosion if battery is replaced by an incorrect type. Dispose of used batteries according to the instructions.
- Please keep the batteries out of the reach of children to prevent from swallowing

batteries, which might cause poisoning.

- Once the battery's color changes or its shape is twisted, please stop using it.

## **USB adapter Information**

- Do not expose the adapter to high temperatures or moisture places. Otherwise, it may cause fire or electric shock.
- Do not attempt to repair, disassemble, change or transform the adapter.
- Avoid sudden changes in temperature, which may cause condensation on the adapter's internal surfaces. Please do not use it immediately in this situation.
- Do not touch the plug with wet hands. Otherwise, it may cause electric shock.
- Do not use the travel voltage converter or AC/DC power inverter. Otherwise, it may cause damage, overheating, malfunction or fire to the camera.

## 1.1 Camcorder Interface

**[Front View]**

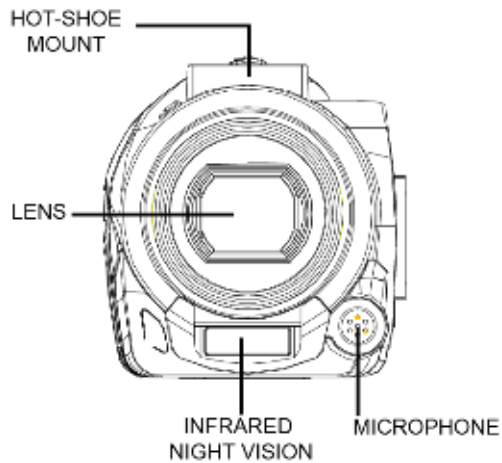

**[Rear View]**

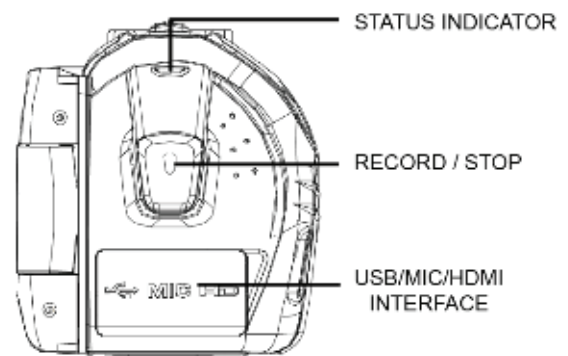

**[Top View]**

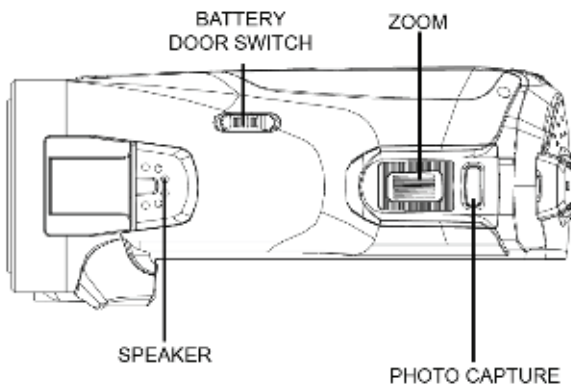

**[Bottom View]**

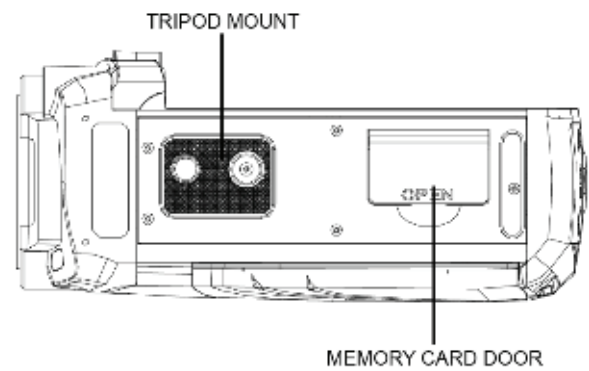

**[Side View]**

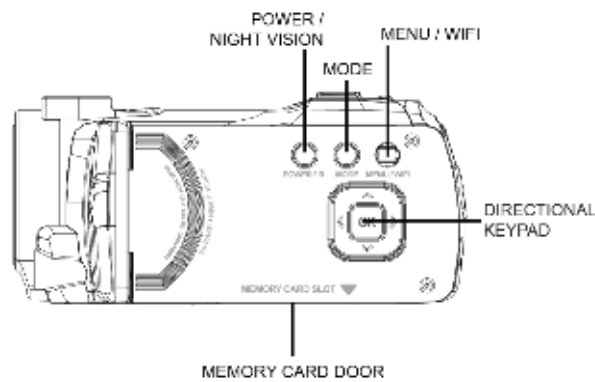

## 1.2 Button Function Description

Function	Description
Power   IR	Press for 3 seconds to power on or off. Tap once to enable or disable IR night vision.
Mode	Press to cycle between Video, Photo, Playback and Setup modes.
Menu   WIFI	Press to access and exit all menus and submenus. Press for 3 seconds to enter WiFi mode.
Zoom	<p><b>In Video or Photo:</b> Press right to zoom-in. Press left to zoom-out.</p> <p><b>In Playback Mode:</b> Press to view 9 images on the screen.</p> <p><b>In Video Playback:</b> Press to raise and lower the playback volume.</p> <p><b>In Photo Playback:</b> Press to zoom in and out of a photo.</p>
Photo	<p><b>In Photo:</b> Press to capture a photo.</p> <p><b>In Video:</b> Press to pause and resume recording.</p> <p><b>In Video Playback:</b> Press to pause and resume the video.</p>
Record	<p><b>In Video:</b> Press to start and stop recording video.</p> <p><b>In Video Playback:</b> Press to start and stop the video.</p>
Directional Pad	<p><b>In Menus:</b> Use the UP, Down, Left and Right buttons to scroll through menus and options.</p> <p><b>In Video and Photo Modes:</b> Press the Up or Down buttons to adjust the exposure value. Press the Left button to hide the icons from the screen, press the Left button again to show them.</p>
OK	Press to enter sub menus and to select menu options
Infrared Night Vision	Infrared LED to aid with vision and recording in darkness.
Tripod Mount	Mount port for attaching to a tripod nut.
Memory Card Door	Door to cover storage slot for inserting a memory card.

Battery Door	Door to cover the battery compartment.
Speaker	Built-in speaker output for playback of video files when audio recording is enabled.
Lens	Front capture device for all video and photo.

## 2. First Use

### 2.1 Inserting the Memory Card

Insert the included SD memory card to record and store your videos and photos. When the battery is low, media stored on the memory card will not be erased. Please insert the SD memory card by following the steps below:

1. Open the memory card door on the bottom by lifting from the side that says "OPEN".
2. Insert the memory card. Ensure that the metal contacts are inserted first. Push the memory card in until you hear an audible click.  
**The memory card can only be inserted in one way. Do not force the card in if it will not go in smoothly.**
3. Close the memory card door.
4. To remove the memory card, simply push in and the card will eject back out.

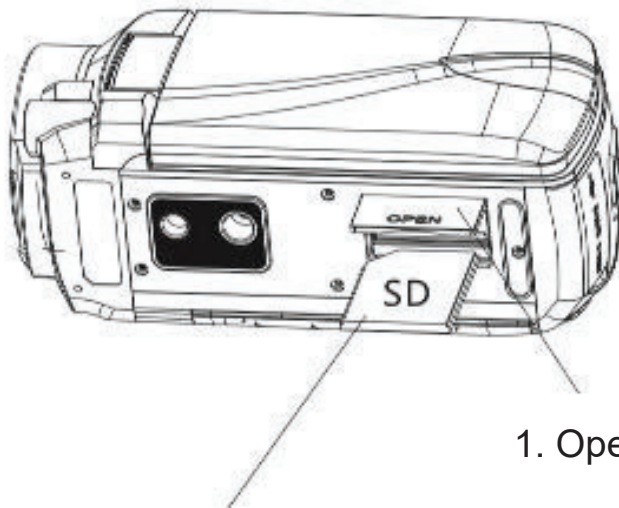

1. Open the memory card door

2. Insert the memory card as shown

### NOTE:

- Please format the memory card before using the camcorder (Caution, this will erase all data on the card).
- Do not remove or insert the memory card when recording. It may damage the card or cause data loss.
- Memory card rating must be Class 10 or above.

### 2.2 Installing the Battery

**The included battery should be fully charged before using your camcorder for the first time.**

Insert the included battery into the battery compartment with the battery's metal contacts aligned with the camcorder's metal contacts. You will know it is in the correct position if the battery reads "Battery Pack for Fuji NP120". If not, you have the wrong side inserted in the camera. Inserting the battery incorrectly will prevent your battery from charging and your camcorder from operating.

Attention!

Please insert the battery in the correct way!

1. Slide the battery door switch forward to open the battery door.

3. Close the battery door.

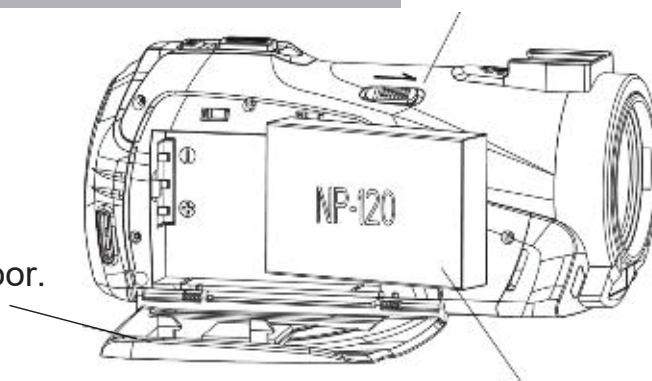

2. Insert the Li-ion battery into the compartment as shown. Make sure the contacts face the rear of the camcorder.

### 2.3 Charging the Battery

1. After installing the battery, connect your camcorder to the included USB cable and AC adaptor. Plug the small end of the USB cable into the



camcorder's USB port, and the larger USB cable end into the included AC adaptor. Once plugged in successfully, the camcorder's status LED will illuminate in green. When the green light goes off, the battery is fully charged.

2. To conserve battery power, be sure to set the Power Save setting duration in the setup menu. To enable this setting, follow these directions:
  - a. Power your camcorder on and press the MODE button three times to enter Setup mode. You will notice the Mode icon change in the top left-hand corner of the screen. A menu will also display on the screen.
  - b. Once in Setup Mode, use the UP or DOWN buttons to navigate and select 'Power Save'. Press the OK button to enter the 'Power Save' submenu.
  - c. Press the UP or DOWN buttons to navigate the submenu and press the OK button to confirm your selected setting (Off, 1 Minute, 3 Minutes, 5 Minutes).
3. To further conserve battery power, remove the battery when the camcorder will be stored for a prolonged period.
4. When not in use, keep your battery at room temperature and avoid exposure to extreme heat or cold.

### 2.4 Powering the Camcorder On/Off

Hold the POWER button for 3 seconds to power the camcorder on. To power the camcorder off, press and hold the POWER button for a further 3 seconds.

The camcorder will automatically power on and off when the screen is opened or closed. If the camcorder's battery is low, a "Low Power" message will display on the screen and it will automatically shut down within a few seconds to prevent memory corruption or loss.

### 2.5 Switching Modes

Press the MODE button to cycle between Video, Photo, Playback and Setup Modes. The corresponding mode will be displayed in the top left corner of the screen.

### 2.6 Connecting to a Computer

Your camcorder can connect to a computer to transfer photo and video files for viewing and editing, as shown below. Once connected and powered on, the camcorder's screen will enter "Mass Storage" mode automatically.

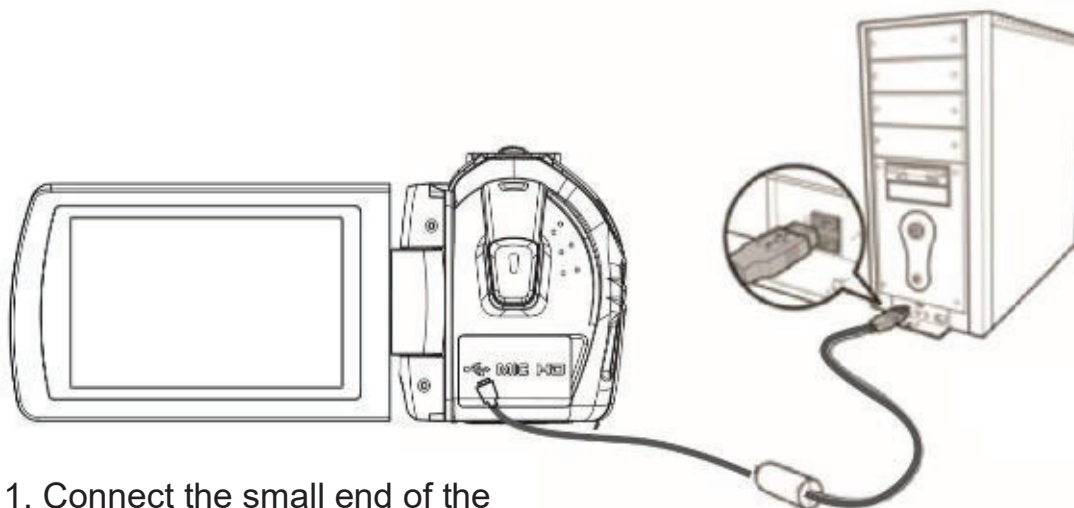

1. Connect the small end of the USB cable to the USB port on the camcorder.

2. Connect the large end of the USB cable to the USB port on the computer.

### 2.7 Connecting to a TV

The camcorder can also be connected to a TV. When connected, the camcorder screen will turn off and the camcorder will function normally. Use the TV as the camcorder monitor.

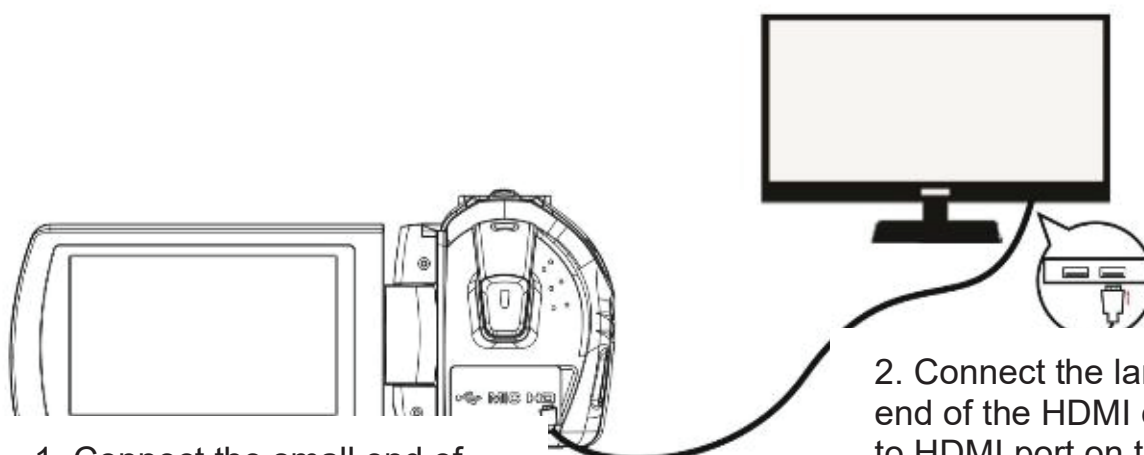

1. Connect the small end of the HDMI cable to HDMI port on the camcorder.

2. Connect the large end of the HDMI cable to HDMI port on the TV.

### 2.8 Video Mode

Press the MODE button to switch to Video Mode. The meaning of each icon within Video Mode is explained in the table below:

1) Video Mode	6) Recording Time
2) Video Quality Indicator	7) Memory Card Inserted
3) Exposure	8) Battery Level
4) Video Size (Resolution)	9) IR LED Light Indicator
5) Frame Rate	10) WiFi Indicator



### 2.9 Photo Mode

Press the MODE button to switch to Photo Mode. The meaning of each icon within Photo Mode is explained in the table below:

1) Photo Mode	5) Photo Size (Resolution)	9) Battery Level
2) White Balance	6) Photo Quality Indicator	10) IR LED Light
3) Metering	7) Remaining Image Space	11) WiFi Indicator
4) Exposure Value	8) Memory Card Inserted	



### 2.10 Using the Zoom Function

This camcorder has a digital zoom function. To operate the zoom function, slide the ZOOM button right to zoom in closer to the subject, and to the left to zoom away from the subject.

### 2.11 Using the IR Night Vision Mode

This camcorder has built-in infrared (IR) LEDs for night vision recording - giving you the ability to capture photos and videos in a dark environment.

In Photo or Video mode, short-press the POWER/IR button once to enable the IR LED light. When the IR LED light is enabled, the IR LED light indicator on the left of the screen will display in white.

To disable the IR light, short-press the POWER/IR button again. You will notice that the IR light indicator on the screen will now be grayed out.

**Note:**

The photos and videos taken while the IR LED is enabled will be recorded in black and white.

The IR LED cannot be enabled or disabled during a recording.

### 2.12 Attaching External Accessories

This camcorder supports lens filters & attachments. Simply utilize the front lens diameter 37mm threading for any desired attachments.

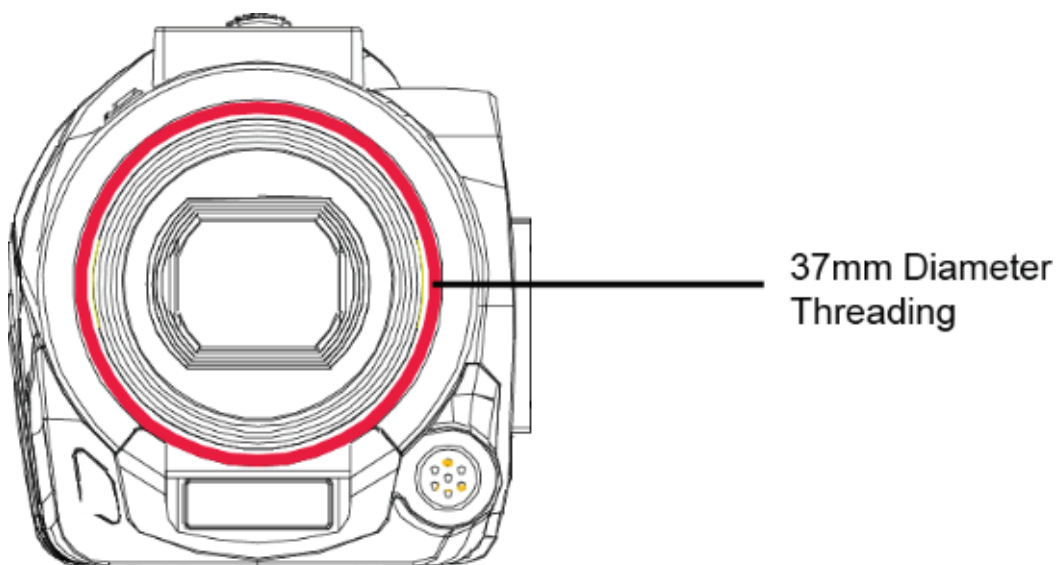

### 3. Using the Camcorder

#### 3.1 Video Recording

Power the camcorder on and it will be ready to record clips right away. You may press the MODE button to switch to another mode. A camcorder icon will appear in the top left hand corner of the screen when you are in Video mode.

1. Line up your shot by looking at the LCD screen to see what is in view.
2. Hold the camcorder steady and press the RECORD button to begin recording.
3. When recording begins, a rolling timer will display in red in the top right hand corner of the screen. This indicates the recorded video time elapsed.
4. Press the PHOTO button to pause and resume recording. Press the RECORD button to stop recording.
5. The status LED will blink Red slowly while recording and will be solid Red if the recording is paused.
6. The recorded video files will automatically save onto the inserted memory card.

#### MOVIE SHOOTING TIPS:

- **Movie Quality:** The overall color and fidelity of your movies will vary by the amount and quality of light in the scene you're shooting. While this is almost never an issue when shooting outdoors in bright light, a dimly light room indoors will not record colorful movies. We suggest you "brighten" the scene by either turning on more lights in the room or using a Video LED Light for extra light in the scene.
- **IR Night Vision Lighting:** The camera has a built in Infra-Red light that allows for movies to be shot in total darkness. IR Mode movies are in black and white only. To use this feature, press the big silver button (Power button) on the left side of the camera once. You will not see the IR red light come on as IR lights are invisible to the naked eye. Remember to turn it off when not in use as the movies will be shot in black and white, and the battery will discharge more rapidly than in other modes.

#### 3.1.1 Movie Size (Resolution)

Your camcorder has a number of preset resolutions and frames per second rates.

1. In Video Mode press the MENU button.
2. Select 'Movie Size' using the UP or DOWN buttons and press the OK button to enter the 'Movie Size' submenu.

3. Press the UP or DOWN buttons to navigate the menu and press the OK button to confirm your selected setting (*1080P 30fps, 720P 60fps, 720P 30fps, 480P 60fps*). A higher resolution and faster frames per second rate will produce a higher quality and larger video file.

### 3.1.2 Video Quality

The Video Quality function determines the level of compression the camcorder uses when saving videos to a memory card.

1. In Video Mode press the MENU button.
2. Select '*Video Quality*' using the UP or DOWN buttons and press the OK button to enter the '*Video Quality*' submenu.
3. Press the UP or DOWN buttons to select the required quality option (*Super Fine, Fine, Normal*), and press the OK button to confirm your selected image option. Fine uses the least amount of compression for saving, and as a result produces a higher video quality.

### 3.1.3 Loop Record

This function allows you to set a maximum duration for each video clip recorded.

1. In Video Mode press the MENU button.
2. Select '*Loop Record*' using the UP or DOWN buttons and press the OK button to enter the '*Loop Record*' submenu.
3. Press the UP or DOWN buttons to select the required loop duration option (*Off, 1 Minute, 3 Minutes, 5 Minutes*), and press the OK button to confirm your selected option.

*Once you select an option, your camcorder will record video clips in this interval only. Once this duration is reached, the camcorder will seamlessly end recording and begin recording a new video file.*

### 3.1.4 White Balance

White Balance changes the color of light in your pictures, making it seem warmer or cooler depending on how the light you're shooting in affects the frame.

1. In Video Mode press the MENU button.
2. Select '*White Balance*' using the UP or Down buttons and press the OK button to enter the '*White Balance*' submenu.
3. Press the UP or DOWN buttons to navigate the menu, and press the OK button to confirm your selected setting (*Auto, Daylight, Cloudy, Incandescent, Fluorescent, Fluorescent L*).

### 3.1.5 Exposure

This function adjusts the frame brightness in your video.

1. In Video Mode press the MENU button.

2. Select '*Exposure*' using the UP or Down buttons and press the OK button to enter the '*Exposure*' submenu.
3. Press the UP or DOWN buttons to navigate the menu, and press the OK button to confirm your selected exposure mode (-2.0, -1.7, -1.3, -1.0, -0.7, 0.0, +0.3, +0.7, +1.0, +1.3, +1.7, +2.0).

### 3.1.6 Video Stabilization

This function enables photo capture in high speed and low-light by electronically minimizing motion blur and reducing camera shake.

1. In Video Mode press the MENU button.
2. Select '*Video Stabilization*' using the UP or Down buttons and press the OK button to enter the '*Video Stabilization*' submenu.
3. Press the UP or DOWN buttons to navigate the menu, and press the OK button to confirm your selected option (*Off, On*).

### 3.1.7 Metering

Metering mode refers to the way in which a camera determines the appropriate exposure (quantity of light reaching the camcorder lens). Spot metering will only base the exposure setting on a very small area of the scene. Center-Weighted metering will use the light from the center of the LCD and the Multi setting measures the light at several points on the screen.

1. In Video Mode press the MENU button.
2. Select '*Metering*' using the UP or DOWN buttons and press the OK button to enter the '*Metering*' submenu.
3. Press the UP or DOWN buttons to select the required Metering option (*Center, Multi, Spot*), and press the OK button to confirm your selected option.

### 3.1.8 Video Effect

This function sets the color filter effect of a video.

1. In Video Mode press the MENU button.
2. Select '*Video Effect*' using the UP or DOWN buttons and press the OK button to enter the '*Video Effect*' submenu.
3. Press the UP or DOWN buttons to navigate the menu, and press the OK button to confirm your selected filter (*Normal, Black & White, Sepia, Negative, Red, Green, Blue*).

### 3.1.9 Slow Motion

This function sets the frame rate of the recorded video to a much slower 10 frames per second.

1. In Video Mode press the MENU button.
2. Select '*Slow Motion*' using the UP or DOWN buttons and press the OK button to enter the '*Slow Motion*' submenu.
3. Press the UP or DOWN buttons to navigate the menu, and press the OK button to confirm your selected setting (*Off, On*).

### 3.1.10 Time Lapse

This feature allows you to capture long sequences of events in a much shorter time period.

1. In Video Mode press the MENU button.
2. Select '*Time Lapse*' using the UP or DOWN buttons and press the OK button to enter the '*Time Lapse*' submenu.
3. Press the UP or DOWN buttons to navigate the menu, and press the OK button to confirm your selected setting (*Off, Interval of 3 Seconds, 5 Seconds, 10 Seconds, 30 Seconds, 1 Minute*).

**NOTE: By selecting '10 Sec' the camera will capture a photo every 10 seconds and create a time-lapse video. To disable Time-Lapse recording, select 'Off' in this submenu.**

### 3.1.11 Time Lapse Duration

The duration for the time lapse setting is determined in the menu. The option chosen here will record for the chosen duration.

1. In Video Mode press the MENU button.
2. Select '*Time Lapse Duration*' using the UP or DOWN buttons and press the OK button to enter the '*Time Lapse Duration*' submenu.
3. Press the UP or DOWN buttons to navigate the menu, and press the OK button to confirm your selected option (*Unlimited, 5 Minutes, 10 Minutes, 15 Minutes, 20 Minutes, 30 Minutes, 60 Minutes*).

For example, by selecting 15Min the camera will record for 15 minutes of real time. **If 10 Sec is selected in the previous menu, the camera will capture a photo every 10 seconds for 15 minutes.**



### 3.2 Photo Shooting

Power the camcorder on and press the MODE button or press the icon in the top left hand corner of the screen to switch to Photo mode.

1. Line up your shot by looking at the LCD screen to see what is in the shot.
2. Hold the camera steady and press the PHOTO button to capture a photo.
3. The status LED will blink Red once when a photo is taken.
4. The number of photos that can be captured at a particular resolution will be displayed in the top right corner of the screen.
5. A “no card” message will be displayed on the screen if there is no SD card inserted in the camcorder’s memory card slot. A “storage card full” message will be shown on the screen when the SD card is full.
6. The number of remaining photos is determined by the selected photo resolution. The higher the photo resolution, the lower the number of photos you are able to be save to the memory card. Before capturing any photos, you can select a preferred photo resolution.

#### 3.2.1 Resolution (Photo Size)

This function sets the photo resolution. The higher the resolution, the greater the photo quality and the larger the file size of the photo.

1. In Photo Mode press the MENU button.
2. Select ‘*Resolution*’ using the UP or DOWN buttons and press the OK button to enter the ‘*Resolution*’ submenu.
3. Press the UP or DOWN button to select a resolution, and press the OK button to confirm the selected photo resolution (*24MP, 20MP, 16MP, 12MP, 10MP, 8MP, 7MP, 5MP, 3MP, 2MP*).

#### 3.2.2 Quality

The Photo Quality function determines the level of compression the camcorder uses when saving photos to a memory card.

1. In Photo Mode press the MENU button.
2. Select ‘*Quality*’ using the UP or DOWN buttons and press the OK button to enter the ‘*Quality*’ submenu.
3. Press the UP or DOWN buttons to select the required quality option (*Super Fine, Fine, Normal*), and press the OK button to confirm your selected image option. Super Fine uses the least amount of compression for saving, and as a result produces a higher photo quality.

#### 3.2.3 Metering

Metering mode refers to the way in which a camera determines the appropriate exposure (quantity of light reaching the camcorder lens). Spot metering will only base the exposure setting on a very small area of the

scene. Center-Weighted metering will use the light from the center of the LCD and the Multi setting measures the light at several points on the screen.

1. In Photo Mode press the MENU button.
2. Select '*Metering*' using the UP or DOWN buttons and press the OK button to enter the '*Metering*' submenu.
3. Press the UP or DOWN buttons to select the required Metering option (*Center, Multi, Spot*), and press the OK button to confirm your selected option.

### 3.2.4 White Balance

White Balance changes the color of light in your pictures, making it seem warmer or cooler depending on how the light you're shooting in affects the frame.

1. In Photo Mode press the MENU button.
2. Select '*White Balance*' using the UP or DOWN buttons and press the OK button to enter the '*White Balance*' submenu.
3. Press the UP or DOWN buttons to navigate the menu, and press the OK button to confirm your selected setting (*Auto, Daylight, Cloudy, Incandescent, Fluorescent, Fluorescent L*).

### 3.2.5 ISO

This function adjusts the light sensitivity in your photograph.

1. In Photo Mode press the MENU button.
2. Select '*ISO*' using the UP or DOWN buttons and press the OK button to enter the '*ISO*' submenu.
3. Press the UP or DOWN buttons to navigate the menu, and press the OK button to confirm your selected ISO (*Auto, 50, 100, 200, 400*).

### 3.2.6 Exposure

This function adjusts the frame brightness in your photograph.

1. In Photo Mode press the MENU button.
2. Select '*Exposure*' using the UP or DOWN buttons and press the OK button to enter the '*Exposure*' submenu.
3. Press the UP or DOWN buttons to navigate the menu, and press the OK button to confirm your selected exposure mode (*-2.0, -1.7, -1.3, -1.0, -0.7, -0.3, 0.0, +0.3, +0.7, +1.0, +1.3, +1.7, +2.0*).

### 3.2.7 Self-Timer

This function determines the time delay before a photograph is captured. This setting can be used by photographers to take photographs of

themselves.

1. In Photo Mode press the MENU button.
2. Select '*Self Timer*' using the UP or DOWN buttons and press the OK button to enter the '*Self Timer*' submenu.
3. Press the UP or DOWN buttons to navigate the menu, and press the OK button to confirm your selected option (*Off, 2 Seconds, 10 Seconds, Double*).

### 3.2.8 Photo Burst

This function allows to you capture consecutive photos with one click of the PHOTO button.

1. In Photo Mode press the MENU button.
2. Select '*Photo Burst*' using the UP or DOWN buttons and press the OK button to enter the '*Photo Burst*' submenu.
3. Press the UP or DOWN buttons to navigate the menu, and press the OK button to confirm your selected setting (*Off, 3, 5, 10*).

### 3.2.9 Sharpness

This function adjusts the visible detail of a photograph.

1. In Photo Mode, press the MENU button.
2. Select '*Sharpness*' using the UP or DOWN buttons and press the OK button to enter the '*Sharpness*' submenu.
3. Press the UP or DOWN buttons to navigate the menu, and press the OK button to confirm how sharp you would like your photograph to be (*Hard, Normal, Soft*).

### 3.2.10 Photo Effect

This function sets the color filter effect of a photograph.

1. In Photo Mode press the MENU button.
2. Select '*Photo Effect*' using the UP or DOWN buttons and press the OK button to enter the '*Photo Filter*' submenu.
3. Press the UP or DOWN buttons to navigate the menu, and press the OK button to confirm your selected filter (*Normal, B&W, Sepia, Negative, Red, Green, Blue*).

### 3.2.11 Date/Time Stamp

This function adds a date/time stamp to your photographs.

1. In Photo Mode press the MENU button.
2. Select '*Date/Time Stamp*' using the UP or DOWN buttons and press the OK button to enter the '*Date/Time Stamp*' submenu.
3. Press the UP or DOWN buttons to navigate the menu and the OK

button for your selected setting (*Off, Date, Date and Time*). Section 3.3.4 explains how to set the time & date on your camcorder.

***Note that once a date/time stamp is captured on a photograph, it cannot be removed.***

### 3.2.12 Image Stabilization

This function enables photo capture in high speed and low-light by electronically minimizing motion blur and reducing camera shake.

1. In Photo Mode press the MENU button.
2. Select '*Image Stabilization*' using the UP or DOWN buttons and press the OK button to enter the '*Image Stabilization*' submenu.
3. Press the UP or DOWN buttons to navigate the menu, and press the OK button to confirm your selected option (*Off, On*).

### 3.2.13 Scene Modes

This function adjusts the camera's settings to predetermined values that will produce the best image for that selected scene.

1. In Photo Mode press the MENU button.
2. Select '*Scene Modes*' using the UP or DOWN buttons and press the OK button to enter the '*Scene Modes*' submenu.
3. Press the UP or DOWN buttons to navigate the menu, and press the OK button to confirm your selected option (*Auto, Landscape, Portrait, Sport, Flower, Beach, Aquarium, Snow, Sunset, Night Scene, Fireworks*).

### 3.2.14 Face Detection

This function allows you to set your camera to detect faces in a scene and adjust your camera's setting for the most optimal picture. You can also enable your camera to capture a photo once a smile is detected on the faces in a scene.

1. In Photo Mode press the MENU button.
2. Select '*Face Detection*' using the UP or DOWN buttons and press the OK button to enter the '*Face Detection*' submenu.
3. Press the UP or DOWN buttons to navigate the menu, and press the OK button to confirm your selected option (*Off, On, Smile Detect*). The On setting will enable Face Detection. The Smile Detect setting will enable your camera to capture a photo once a smile is detected on the faces in a scene.

### 3.2.15 Time Lapse

This function allows you to capture a long sequence of events in a much shorter time period. This specific setting will determine how often an image is

automatically captured.

1. In Photo Mode, press the MENU button.
2. Select '*Time Lapse*' using the UP or DOWN buttons and press the OK button to enter the '*Time Lapse*' submenu.
3. Press the UP or DOWN buttons to navigate the menu, and press the OK button to confirm your selected option (*Off, 3 Seconds, 5 Seconds, 10 Seconds, 30 Seconds, 1 Minute*). For example, by selecting 10 Sec the camera will capture a photo every 10 seconds for a determined time period as selected in the Time Lapse Duration setting (see next setting).

### 3.2.16 Time Lapse Duration

The duration for the time lapse setting is determined in the menu. The option chosen here will record for the chosen duration.

1. In Photo Mode press the MENU button.
2. Select '*Time Lapse Duration*' using the UP or DOWN buttons and press the OK button to enter the '*Time Lapse Duration*' submenu.
3. Press the UP or DOWN buttons to navigate the menu, and press the OK button to confirm your selected option (*Unlimited, 5 Minutes, 10 Minutes, 15 Minutes, 20 Minutes, 30 Minutes, 60 Minutes*).

For example, by selecting 15 Min, the camera will record for 15 minutes of real time. **If 10 Sec is selected in the previous menu, the camera will capture a photo every 10 seconds for 15 minutes.**

### 3.3 Setup Menu

Basic settings can be changed in the Setup menu. These include date & time, language and sound options. Power the camera on and press the MODE button to switch to setup mode. A menu will display on the screen.

#### 3.3.1 Sounds

This function can set the sound volume on your camcorder.

1. In Setup Mode, use the UP or DOWN buttons to select '*Sounds*' and press the OK button to enter the '*Sounds*' submenu.
2. Press the UP or DOWN buttons to switch between '*Shutter*', '*Beep*' and '*Volume*'. Press the LEFT or RIGHT buttons to change the setting of the '*Shutter*' option (the sound made when a photo is captured), the '*Beep*' option (the sound is made when the camcorder mode is cycled) and the '*Volume*' option (the volume level of the camera sounds).
3. Once you are happy with the sound settings press the OK button confirm your setting and exit the submenu.

#### 3.3.2 Power Frequency

This function sets the frequency of the camcorder from 50Hz to 60Hz.

Please check the frequency of your location and set accordingly.

1. In Setup Mode use the UP or DOWN buttons to select '*Power Frequency*' and press the OK button to enter the '*Power Frequency*' submenu.
2. Press the UP or DOWN buttons to select your desired frequency. Then press the OK button to confirm your selection (*50Hz, 60Hz*). The default frequency for the United States is 60Hz.

#### 3.3.3 Power Save

This function sets the duration of time in which the camcorder will wait with no user input before automatically powering off.

1. In Setup Mode use the UP or DOWN buttons to select '*Power Save*' and press the OK button to enter the '*Power Save*' submenu.
2. Press the UP or DOWN buttons to navigate the menu and then press the OK button to confirm your selected setting (*Off, 1 Minute, 3 Minutes, 5 Minutes*).

#### 3.3.4 Date and Time

This function allows you to set the current Date and Time on your recorded video clips and captured photos.

1. In Setup Mode use the UP or DOWN buttons to select '*Date and Time*' and press the OK button to enter the '*Date and Time*' submenu.

2. Press the LEFT or RIGHT button to switch between year, month, date, hours and minutes.
3. Once highlighted on your desired field, press the UP or DOWN buttons to cycle through numbers.
4. The date format can be changed to display in three formats; YY/MM/DD, DD/MM/YY or MM/DD/YY.
5. Once completed with all of the fields, press the OK button to confirm the changes.

### 3.3.5 Language

This function allows you to set the camcorder's interface language.

1. In Setup Mode use the UP or DOWN buttons to select '*Language*' and press the OK button to enter the '*Language*' submenu.
2. Press the UP or DOWN buttons to select your desired language. Then press the OK button to confirm your selection.

### 3.3.6 TV Output

This function allows you to set how you view your media on your television.

1. In Setup Mode use the UP or DOWN buttons to select '*TV Out*' and press the OK button to enter the '*TV Out*' submenu.
2. Press the UP or DOWN buttons to select your desired setting (*NTSC* for US or Canada or *PAL* for Europe). Then press the OK button to confirm your selection.

### 3.3.7 Format

The format setting erases all photos, videos and data stored on your memory card.

1. In Setup Mode use the UP or DOWN buttons to select '*Format...*' and press the OK button to enter the '*Format...*' submenu.
2. Press the UP or DOWN buttons to select your desired selection, press the OK button for your selected setting (*Yes*, *No*).

**NOTE: This will delete all of your media and cannot be undone.**

### 3.3.8 Reset All

Factory default settings can be restored in this menu. This function will not delete the media stored on the memory card, and will only restore all of the menu's setting back to factory default settings.

1. In Setup Mode use the UP or DOWN buttons to select '*Reset All...*' and press the OK button to enter the '*Reset All...*' submenu.
2. Press the UP or DOWN buttons to select your desired option, then press

the OK button to confirm your selection (*Yes, No*).

### 3.4 Playback Mode

Videos and photos captured on your camcorder can be easily played back. The status LED will be solid RED while in Playback Mode. Power the camcorder on and press the MODE button twice to switch to Playback Mode.

1. Press the LEFT or RIGHT buttons to cycle through the captured videos and photos stored on the memory card.
2. When viewing a photo push the ZOOM button to the right and it will zoom in on the picture on the screen. Use the directional pad to navigate while zoomed in.
3. When viewing a video press the RECORD button to start playback, while the video is playing press the PHOTO button to pause, press the LEFT button to rewind, press the RIGHT button to fast forward and the RECORD button to stop.
4. Push the ZOOM button to the left to view 9 images on the screen at once, use the UP, DOWN, LEFT or RIGHT buttons to navigate and press the OK button on the selected image to view that image on the full screen.

In Playback Mode the following options are available:

#### 3.4.1 Protect

This function protects the photo/video file. The file will be protected from being deleted accidentally. Files must be unprotected to be deleted.

1. In Playback Mode press the MENU button, and use the UP or DOWN buttons to select '*Protect*' and press the OK button to enter the '*Protect*' submenu.
2. Press the UP or DOWN buttons to navigate the menu and press the OK button to confirm your selected setting (*Single, Protect All, Unprotect All*).
3. Press the MENU button to exit the menu without protecting any pictures or videos.

#### 3.4.2 Delete

This function is used to delete photos and videos. Photos and videos can be deleted singly or all at once.

1. In Playback Mode press the MENU button, and use the UP or DOWN buttons to select '*Delete*'. Press the OK button to enter the '*Delete*' submenu.
2. Press the UP or DOWN buttons to navigate the menu, and press the OK button for your selected setting (*Single, All*).



3. Press the MENU button to exit the menu without deleting any pictures or videos.

### 3.4.3 Slideshow

Photographs can be viewed as a slideshow on the camcorder.

1. In Playback Mode press the MENU button, and use the UP or DOWN buttons to select '*Slide Show...*' Press the OK button to enter the '*Slide Show...*' submenu.
2. Press the UP or DOWN buttons to navigate the menu.
3. To change the photo interval, select '*Interval*' and press the LEFT or RIGHT buttons to choose between 1 to 10 seconds.
4. To repeat the images, select '*Repeat*' and press the LEFT or RIGHT buttons to change from '*Off*' to '*On*'.
5. Once your desired settings are selected, use the UP or DOWN buttons to select '*Start*' then press the OK button to start the slideshow.
6. To pause and restart the slide show press the PHOTO button, to cancel the slide show press the RECORD button.
7. To exit the '*Slide Show...*' submenu without starting the slide show, press the MENU button.

### 3.4 Wireless Connectivity

#### 3.5.1 Connecting to the iSmart DV App

To wirelessly operate the MN220NV camcorder you will need to install the “iSmart DV” app on your Android or iOS device.

The camera can be operated remotely by following the steps below:

1. Turn the camcorder on and hold the MENU/WIFI button for 3 seconds to launch the wireless menu. A ‘WiFi Enabled. Now ‘Connect From Smartphone’ message will be displayed on the screen.
2. To close the wireless menu, hold the MENU/WIFI button for 3 seconds.
3. The status LED will blink BLUE while searching for a WiFi connection.
4. Open your phone wireless menu, turn all wireless settings on and connect to the network named “Minolta\_XXXXXX” then join the network, password is 1234567890.

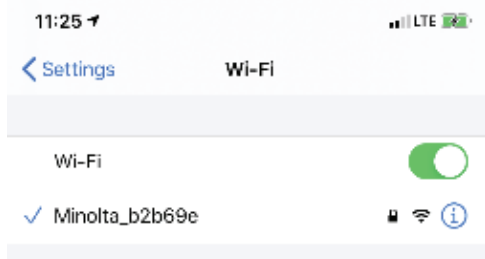

5. A ‘WiFi and Smartphone Connected Successfully’ message will appear on the screen when WiFi is connected.
6. The status LED will be a steady BLUE when connected.
7. Exit the wireless menu and open the “iSmart DV” app to launch remote operation of the camera.
8. Click ‘Add New Camera’ and ‘Wi-Fi Connect’. Once you are successfully connected a preview screen will be shown and you can begin filming.
9. When you return to the homepage your menu should look as shown below:

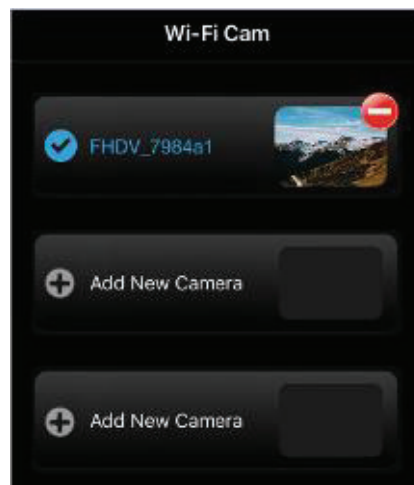

#### 3.5.2 Operating the iSmart DV App

Your MN220NV will now be operable via your smartphone. It will initially default to the video recording function. To change from video, press the camera icon in the bottom right hand corner your phone screen.

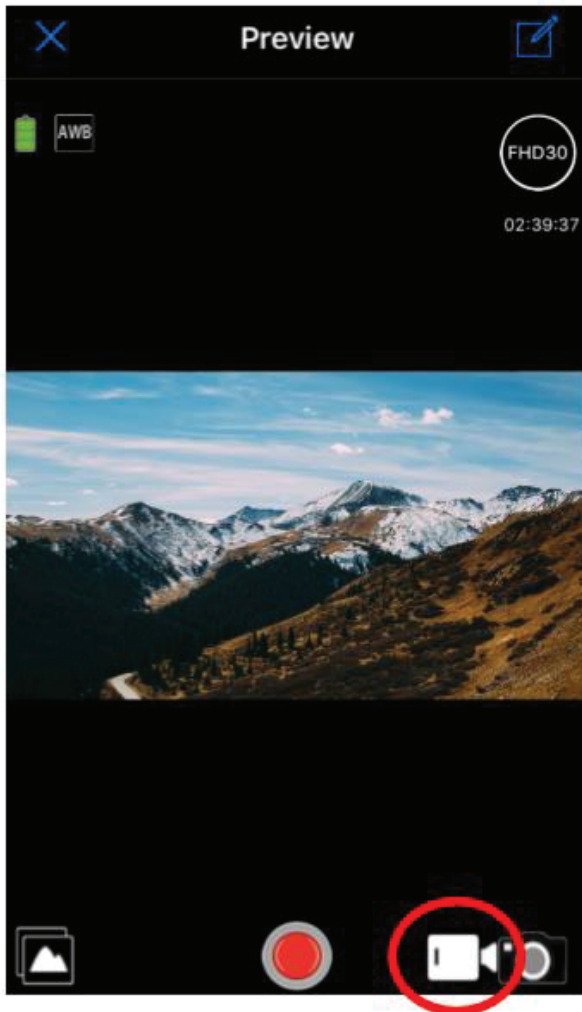

Video function

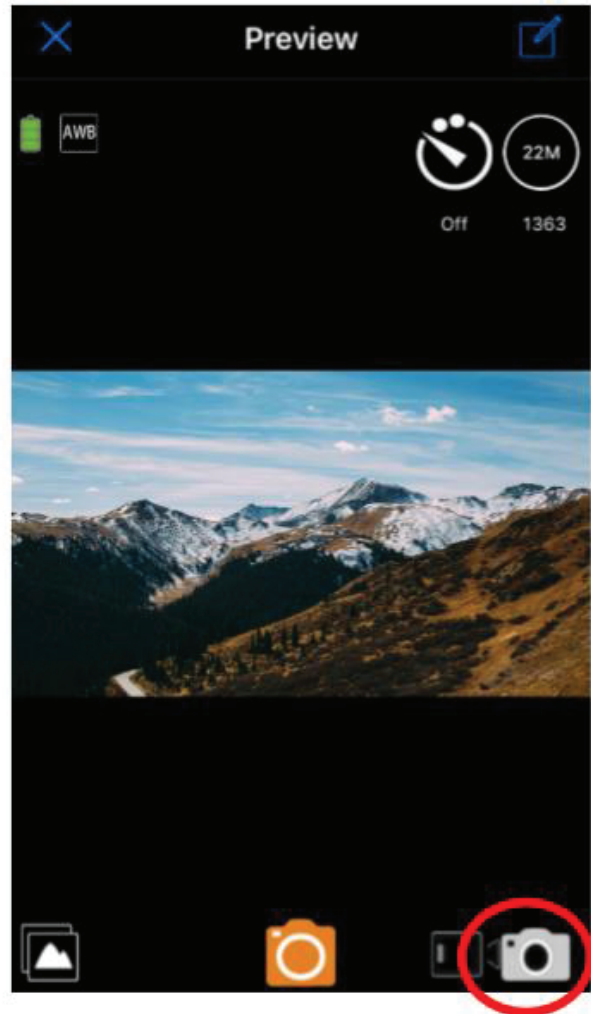
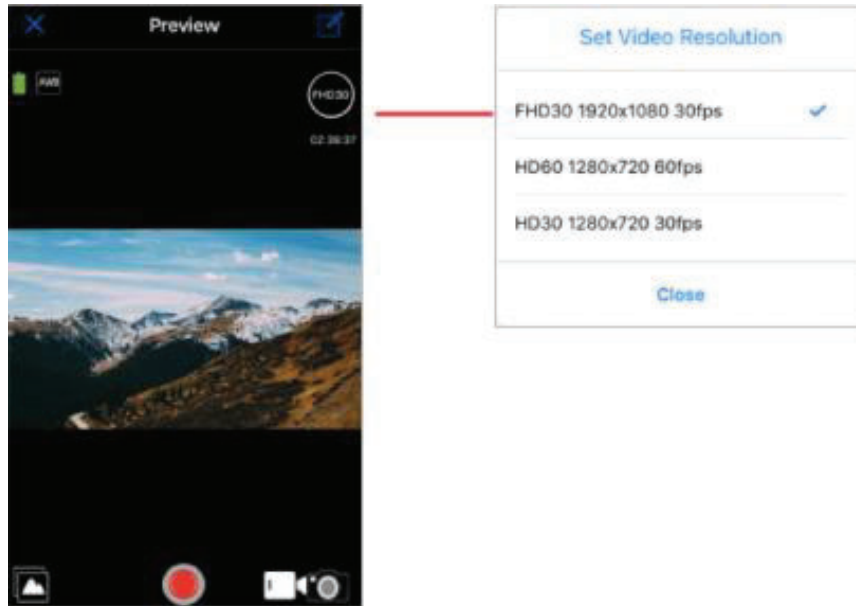

Photo function

##### 3.5.2.1 Recording Videos Remotely

1. To start recording a video, press the record button at the bottom of your smartphone screen. While a video is recording remotely, the operating indicator light at the back of the camcorder will flash red and blue.
2. The video resolution can be changed on the app by pressing the button to the right of the screen. The text in the button will change according to current video resolution. Video resolution can be set at FHD30 1080p 30fps, HD60 720p 60fps, HD30 720p 30fps and VGA60 480p 60fps.



#### 3.5.2.2 Taking Photos Remotely

1. To take a photo, press the capture button at the bottom of your smartphone screen. When a photo is taken, the operating indicator light at the back of the camcorder will flash red twice.
2. The photo resolution can be changed on the app. Press the button at the far right of your smartphone screen to bring up the photo resolution sub menu. Photo resolution can be set at 24MP, 20MP, 16MP, 12MP, 10MP, 8MP, 7MP, 5MP, 3MP, 2MP.

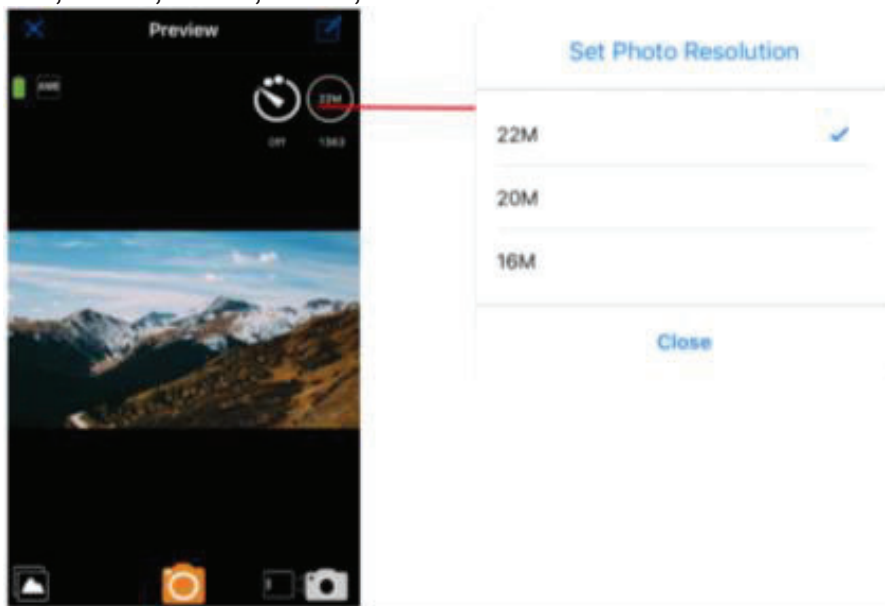

3. Self timer can also be adjusted on the app and can be set to Off, 2S and 10S. Once 2S or 10S is selected, press the capture button. A countdown timer will appear on the camcorder screen to signal the countdown.

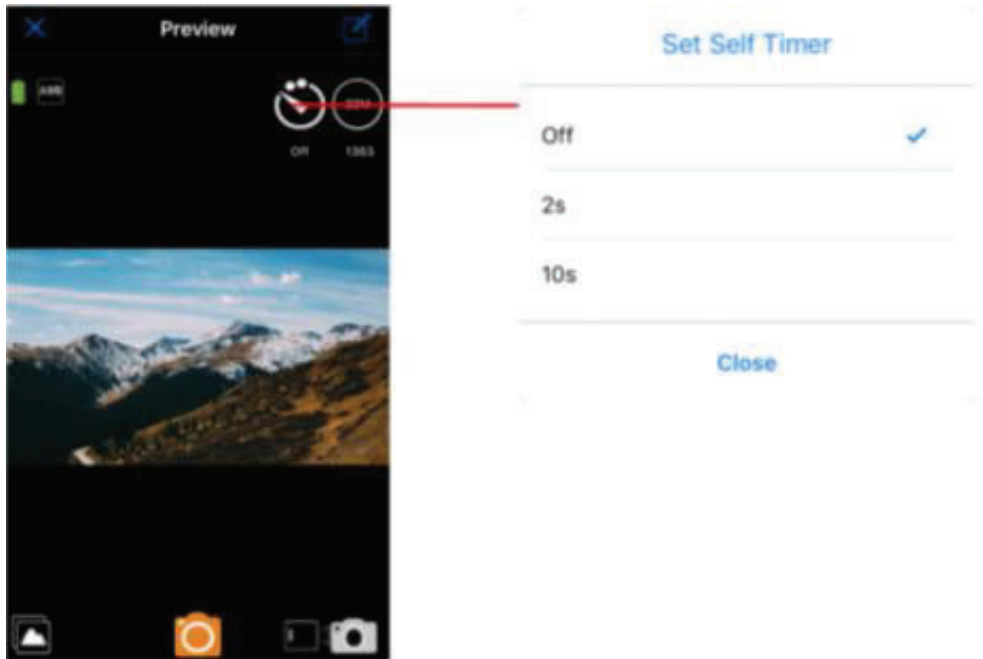

#### 3.5.2.3 Viewing Media on the App

To view your photos and videos on the app, press the photo gallery button in the bottom left corner of the screen. All media on the camcorder will load in two sections; photos and videos. Tap the photo or video file you wish to view. From this screen media can be saved to your smartphone and deleted. If a photo or video is deleted on the app, it will also be removed from the SD card in the camcorder.

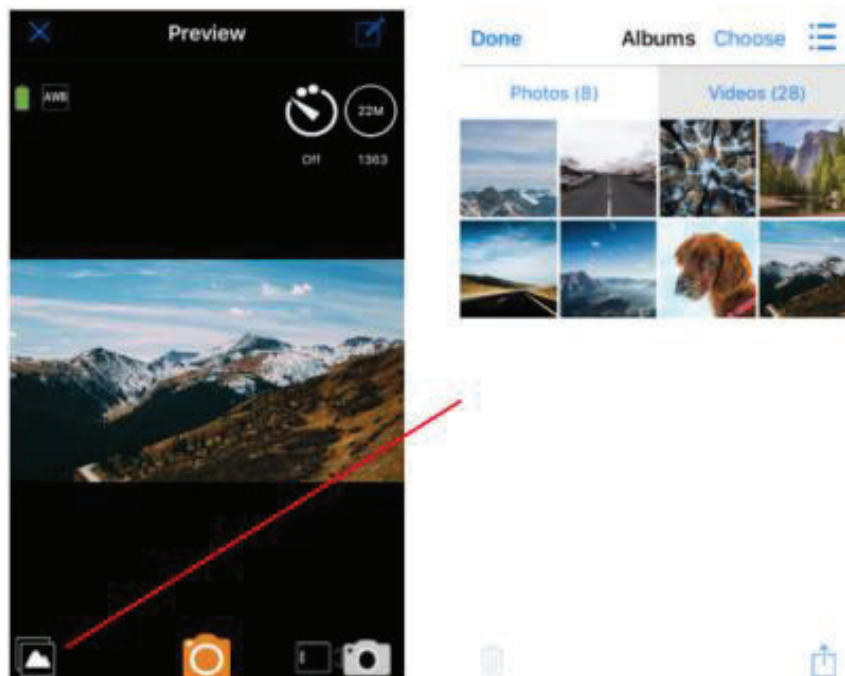

### 3.5.2.4 Changing Camcorder Settings on the App

Camcorder settings can also be changed on the app. Click the icon in the top right hand corner of the screen to launch the settings menu. From here, a number of settings including white balance and frequency can be changed.

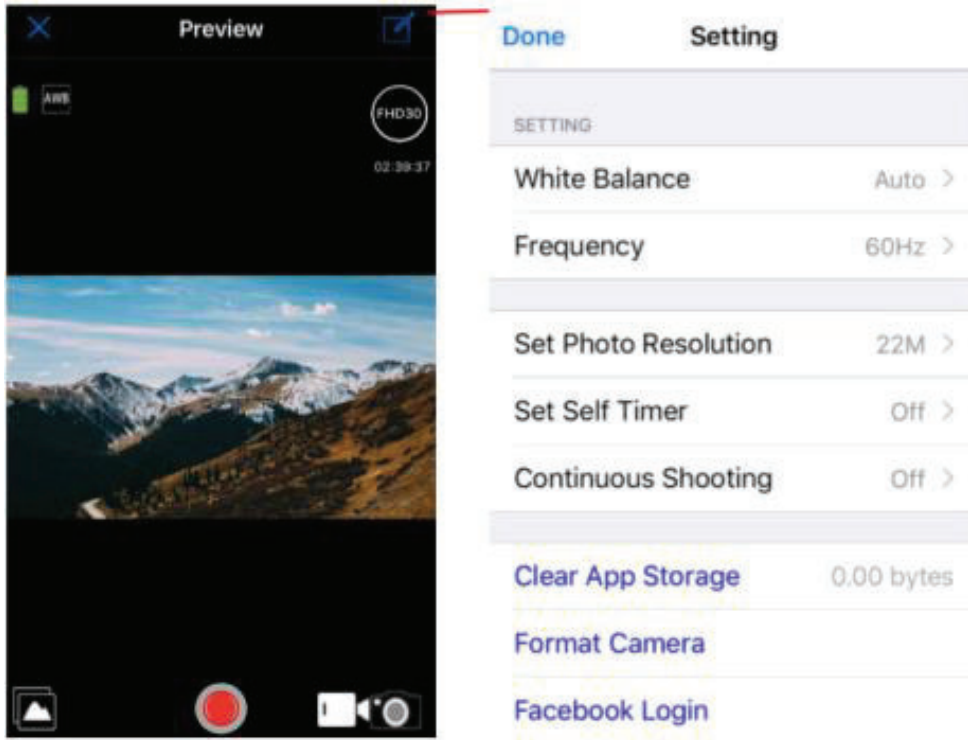

## 4.1 Technical Specifications

<b>Model Number</b>	Minolta MN220NV
<b>Lens</b>	Fixed Focus • f=7.5mm • F/3.2 • 37mm Front Threading for Lens Accessory Attachments
<b>Zoom</b>	16X Digital Zoom
<b>Image Sensor</b>	1/3.2" IMX179 Sony CMOS; 3288x2512 Pixels
<b>Shutter Speed</b>	1/60 ~ 1/30 sec
<b>Shutter</b>	Electronic • Anti-Shake Image Stabilization
<b>Pixels (photo)</b>	JPEG: 24 MP • 20 MP • 16 MP • 12 MP • 10 MP • 8 MP • 7 MP • 5 MP • 3 MP • 2MP • 16:9 (7 MP) • 16:9 (2 MP)
<b>Pixels (video)</b>	MOV: 1080p30fps • 720p60fps • 720p30fps • VGAp60fps
<b>ISO Sensitivity</b>	Auto • 50 • 100 • 200 • 400
<b>LCD Monitor</b>	262k 3.0 Inch 16:9 Wide LCD Screen
<b>WiFi Connection</b>	Yes
<b>Assistive Light</b>	Infrared LED (for shooting in dark scenery)
<b>Power Saving Mode</b>	OFF • 1 Minutes • 3 Minutes • 5 Minutes
<b>White Balance Control</b>	Auto • Daylight • Cloudy • Incandescent • Fluorescent H • Fluorescent L
<b>Scene Modes</b>	Auto • Landscape • Portrait • Sport • Flower • Beach • Aquarium • Snow • Sunset • Night • Fireworks
<b>Special Features</b>	Loop Recording • Slow Motion • Time-Lapse • Photo Burst
<b>Recording Media</b>	SD • SDHC; Maximum: 32GB
<b>I/O Ports</b>	5-pin Mini USB, USB 2.0 (high speed) • Mini HDMI C Type • Microphone (built-in MIC) • Speaker • Microphone Input (3.5mm) • Hot Shoe
<b>Power</b>	NP-120; 3.7v, 1000mAh, 3.7Wh
<b>Dimensions</b>	4.6 x 1.65 x 2.36 in. • 7.02 oz.

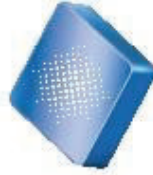

MINOLTA®

*Minolta is a registered trademark of JMM Lee Properties, LLC and is used in the United States by Elite Brands Inc. under license.*

*40 Wall Street, 61st Floor, New York, NY 10005 USA • Tel: 800-441-1100  
www.minoltadigital.com • www.elitebrands.com  
Copyright © 2021 Elite Brands Inc.*

***If you're having difficulties with your camera, or would like further assistance, please call our toll-free technical support hotline at 800-441-1100. Please be sure to have your camera handy when calling.***





